

ECLIPSE II SLIMLINE HE



High Frequency
Eclipse II Plus Slimline
Fast or Opportunity Charging
Eclipse II Slimline
Conventional Charging

The Industry Standard For All Your Charging Needs

- ⚡ Utilizes space efficiently – saves valuable floor space
- ⚡ Optimized to meet stringent new California standards for lowest overall energy usage
- ⚡ Conversion Efficiency balanced for minimum total AC energy usage
- ⚡ Adapts to all battery types and applications with user selectable charge algorithms
- ⚡ Reduced power operating modes minimize power usage when idle
- ⚡ Eclipse II Slimline HE is Datalink2 compatible
- ⚡ Eclipse II Slim-Line Plus opportunity charger has the Datalink2 wireless module built in
- ⚡ UL, cUL and CEC listed

Eclipse II Slimline HE



Inside View



Detail View of CID

The Eclipse II Slimline HE is the most adaptive charging solution on the market, and it maintains the same quality you've come to expect from M-Pulse. The opportunity charging function will sustain the battery between 20% and 80% state of charge via short, opportunistic charges and is able to fully charge your battery in 6 hours or less. Conventional charging mode recharges any fully discharged lead-acid battery within the charger's rated capacity, flooded or sealed, in 8 hours or less.

Advanced IGBT high frequency power conversion circuitry supplies efficient, reliable service in all modes and supports the fast charging capability of the Eclipse II Slimline for when you need your battery available as soon

as possible.

Low Cost Efficient Operation

The high power demands of opportunity chargers require an energy efficient design. The advanced high frequency design of the Eclipse II Slimline is extremely efficient at up to 93%, converting AC power to usable DC power with the minimum possible impact on the utility grid. The .95 power factor minimizes AC amp draw and thereby reduces installation costs.

EC2000 Control

The new EC2000 control is nearly identical in functionality and programmability to M-Pulse's popular UC2000 used in the Ultra product line. With a 40 character, alphanumeric LCD display, easy to read information is always available to follow the charger's status. In addition, 4 bright LEDs provide charge status at a glance and the sealed membrane keypad allows for easy customer interface.

Energy Saving Features

Further enhance energy savings by utilizing the EC2000's programmable start modes. Using the Delayed or Time-of-Day start modes of the EC2000 to charge your batteries during off-peak hours can yield up to 50% in additional energy cost saving. The EC2000 also offers Time-of-Day Block-Out to lower utility bills and reduce peak demand by blocking out a period of charging time on one or more chargers.

Minimize Hydrogen Gas Emissions

The No-Gassing feature of the Eclipse II Slimline allows a programmable time to be set so that should the charger reach the gassing portion of the charge cycle within the set time, the charger would stop charging until the set time has elapsed. Only at this point would the charger continue to charge and take the battery to charge complete.

Automatic or Manual Equalize Operation

All Eclipse II Slimline Series chargers are shipped with Automatic Equalize enabled to ensure that your batteries routinely receive an equalize charge of three hours beyond the normal DV/DT charger termination. Auto Equalize can be set for one of three options: Number of Cycles, Day of Week or BID.

When any automatic equalize function is selected, the equalize button on the keyboard is disabled to prevent unnecessary equalize charges. The ability to automatically equalize batteries provides an exact schedule of equalize charges for better battery maintenance and longer life.

BID Equalization Function

When an M-Pulse BID is attached to the battery, it tracks and records completed charge cycles. When the battery is connected to the charger, it reads the BID information to determine how many charge cycles have been completed since it was last equalized. When the number of completed cycles matches the user selected equalize interval, the charger will equalize that battery. This ensures that each battery is equalized at the intervals selected by the customer regardless of which charger is connected.

Battery Cool Down

Battery cool down allows the battery to cool down before use, which allows for increased control of battery rotation, resulting in increased battery efficiency and longer life. Battery cool down can be programmed from the EC2000 keypad from 0-8 hours in one hour increments. After the recharge is complete, the display will read "battery cool down" until the predetermined cool down period has ended, at which time the charge complete LED is illuminated.

Regulation

The Eclipse II Slimline Series is designed to hold the finish current to within +/-2% over a wide range of line voltage variations.

Mounting Options

The Eclipse II Slimline comes with removable legs and wall mounting brackets for shelf or wall mounting.

Quiet Fan Cooling

The charger utilizes an advanced fan design to cool the electronics, extending life while providing low sound levels for quiet operation.

3 Year Full Warranty

Repair costs are minimized through a 3 year full warranty for the original purchaser. Warranty covers labor, travel, and parts replacement.



Prevent Overcharging

Back-up timers protect your batteries from overcharging by shutting the charger off in the event that the battery does not reach 80% charged in 9 hours, or does not reach charge complete within 4 hours of reaching the 80% charged point. The charger also monitors the ampere hours returned and if the ampere hours returned exceed the rated ampere hour capacity by 125%, the charger will shutdown, protecting your battery from harmful overcharging. (150% on equalize cycles.)

Charge Cycle Archive

The charger will collect and save 21 items of charge cycle information for the last 500 charge cycles. This valuable information can then be reviewed manually from the front panel, or it can also be downloaded wirelessly using our Datalink2 system.

Operating Modes

Multi-cell: automatically matches output voltage to battery

Fixed-cell: set for specific battery voltage, rejects others

BID mode: information programmed in BID determines charger operation

Timer Start: operated as a manual timer for maintenance and shop charging

Refresh Charge

Start off the week with fully charged batteries. Anytime the battery is left plugged into the charger for an extended time, such as over a long weekend, the charger will restart automatically and top off the battery to ensure your trucks are running at peak performance.

Monitor Battery and Charger Operation

With no spare batteries, it's important to know that your batteries are being properly charged and maintained. The functionality of the Eclipse II Series chargers can be greatly enhanced through the addition of the optional Battery Identification Module, BID. The BID is programmed with battery information including rated AH capacity, rated voltage, battery type, and start rate for opportunity charging.

Batteries with BID's will be automatically recognized by the charger, allowing the charger to charge at the proper voltage and current levels for the type of battery connected. The BID eliminates any manual charger settings. The Eclipse II Series charger charges all battery types.

BID with Electrolyte Sensor

The addition of an electrolyte sensor to the standard BID allows the charger to sense when the connected battery needs to be checked for electrolyte levels.



At charge complete, the BID will send a signal to the charger that the electrolyte level is low, and the control will display a message instructing the operator to check the battery.

Wireless Fleet Management System

The Eclipse II Slimline Series is Datalink2 compatible and the Eclipse II Plus Slimline has the Datalink2 wireless module built-in. Datalink2 gives you the opportunity to monitor battery usage and identify bad situations before they become problems that lead to down time.

Datalink2 greatly enhances the ability to collect charge and discharge data from the charger. The transfer of data occurs wirelessly utilizing our proprietary wireless network in combination with a powerful transceiver. Typical communication range is 1,500 ft in a normal operating environment and with communication between chargers, this range is doubled to a 3,000 ft radius. The actual range in your facility can vary greatly based on numerous factors. It is not necessary for the system to be integrated into the customer's network.

Battery Identification Module



The functionality of the Eclipse II Slimline Series chargers can be greatly enhanced through the addition of the optional Battery Identification Module, BID.

The BID is programmed with battery information including rated AH capacity, rated voltage, battery type and more.

BID with Ampere Hour Accumulator



When equipped, a battery with an ampere-hour accumulator BID will transmit to the EC2000 control, the updated AH data. The accumulated AHs for both charge and

discharge cycles are stored in the BID along with the lifetime average battery temperature, and is readable from the EC200 control and through the Datalink2 System.

Dimensions

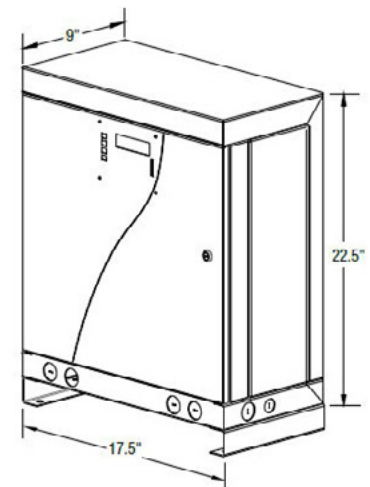

Add 1-1/2" height for removable legs
Add 1-1/2" width for removable wall brackets



Eclipse II HE and EclipseII Plus HE - SLIMLINE - 480VAC Only Models

Number Battery Cells	Model Number	Minimum Battery Amp-Hour Capacity	Maximum Battery Amp-Hour Capacity for 8 Hrs	Maximum DC Output Amps	Phase	AC Input Amps at 480 VAC 60 Hertz-3 ph	Approx. Weight (lbs.)
ECLIPSEII HE-Slimline (conventional charger)							
12	600ES3-12S-HE	510	600	98	3	3.9	70
12	800ES3-12S-HE	510	800	130	3	5.2	70
12	925ES3-12S-HE	510	925	151	3	6.0	70
12	1050ES3-12S-HE	510	1050	171	3	6.9	70
12	1200ES3-12S-HE	510	1200	196	3	7.9	70
12,18	600ES3-18S-HE	510	600	98	3	5.9	70
12,18	800ES3-18S-HE	510	800	130	3	7.8	70
12,18	925ES3-18S-HE	510	925	151	3	9.1	70
12,18	1050ES3-18S-HE	510	1050	171	3	10.3	70
12,18	1200ES3-18S-HE	510	1200	196	3	11.8	70
12,18	1400ES3-18S-HE	510	1400	228	3	13.7	80
18,24	800ES3-24S-HE	595	800	130	3	10.4	80
18,24	925ES3-24S-HE	595	925	151	3	12.1	70
18,24	1050ES3-24S-HE	595	1050	171	3	13.7	70
40	375ES3-40S-HE	300	375	61	3	8.2	70
40	500ES3-40S-HE	400	500	82	3	10.9	70
40	600ES3-40S-HE	510	600	98	3	13.1	70
40	690ES3-40S-HE	510	690	112	3	15.1	70
ECLIPSEII PLUS– Slimline (opportunity charger)							
12	680ES3-12SP-HE	510	680	170	3	6.8	70
12	800ES3-12SP-HE	510	800	200	3	8.0	80
12	900ES3-12SP-HE	510	900	225	3	9.0	80
12	1000ES3-12SP-HE	510	1000	250	3	10.0	80
12,18	680ES3-18SP-HE	510	680	170	3	10.2	70
12,18	800ES3-18SP-HE	510	800	200	3	12.0	80
12,18	900ES3-18SP-HE	510	900	225	3	13.5	80
12,18	1000ES3-18SP-HE	510	1000	250	3	15.0	80
40	375ES3-40SP-HE	300	375	94	3	12.5	70
40	450ES3-40SP-HE	300	450	112	3	15.0	70



EclipseII and EclipseII Plus - SLIMLINE - 480/600VAC

Number Battery Cells	Model Number	Amp-Hour Capacity in 8 Hours	Maximum DC Output Amps	Phase	AC Input Amps at 480 VAC 60 Hertz-3 ph	AC Input Amps at 600 VAC 60 Hertz-3 ph	Approx. Weight (lbs.)
ECLIPSEII – Slimline (conventional charger)							
6,9,12	500ES3-12SC	500	82	3	3.3	2.6	70
6,9,12	600ES3-12SC	600	98	3	3.9	3.1	70
6,9,12	800ES3-12SC	750	130	3	5.2	4.2	70
6,9,12	925ES3-12SC	925	151	3	6	4.8	70
6,9,12	1050ES3-12SC	1050	171	3	6.9	5.5	70
6,9,12	1200ES3-12SC	1200	196	3	7.9	6.3	70
6,9,12,18	600ES3-18SC	600	98	3	5.9	4.7	70
6,9,12,18	800ES3-18SC	800	130	3	7.8	6.2	70
6,9,12,18	925ES3-18SC	925	151	3	9.1	7.3	70
6,9,12,18	1050ES3-18SC	1050	171	3	10.3	8.2	70
6,9,12,18	1200ES3-18SC	1200	196	3	11.8	9.4	80
6,9,12,18	1400ES3-18SC	1400	228	3	13.7	11	80
6,9,12,18,24	500ES3-24SC	500	82	3	6.5	5.2	70
6,9,12,18,24	600ES3-24SC	600	98	3	7.8	6.2	70
6,9,12,18,24	800ES3-24SC	800	130	3	10.4	8.3	70
6,9,12,18,24	925ES3-24SC	925	151	3	12.1	9.7	70
6,9,12,18,24	1050ES3-24SC	1050	171	3	13.7	11	70
12,18,24,36,40*	375ES3-40SC	375	61	3	8.2	6.6	70
12,18,24,36,40*	500ES3-40SC	500	82	3	10.9	8.7	70
12,18,24,36,40*	600ES3-40SC	600	98	3	13.1	10.5	70
12,18,24,36,40*	690ES3-40SC	690	112	3	15.1	12.6	70
ECLIPSEII PLUS– Slimline (opportunity charger)							
6,9,12	550ES3-12SPC	550	138	3	5.5	4.4	70
6,9,12	680ES3-12SPC	680	170	3	6.8	5.4	70
6,9,12	800ES3-12SPC	800	200	3	8	6.4	80
6,9,12	900ES3-12SPC	900	225	3	9	7.2	80
6,9,12	1000ES3-12SPC	1000	250	3	10	8	80
6,9,12,18	550ES3-18SPC	550	138	3	8.3	6.6	70
6,9,12,18	680ES3-18SPC	680	170	3	10.2	8.2	70
6,9,12,18	800ES3-18SPC	800	200	3	12	9.6	80
6,9,12,18	900ES3-18SPC	900	225	3	13.5	10.8	80
6,9,12,18	1000ES3-18SPC	1000	250	3	15	12	80
6,9,12,18,24	550ES3-24SPC	550	138	3	11	8.8	70
6,9,12,18,24	680ES3-24SPC	680	170	3	13.6	10.9	70
6,9,12,18,24	750ES3-24SPC	750	188	3	17	13.6	80
12,18,24,36,40*	375ES3-40SPC	375	94	3	12.5	10	70
12,18,24,36,40*	450ES3-40SPC	450	112	3	15	12	70

*Control does not auto select between 36 and 40 cell.

Dimensions: 17.5" wide x 10.5" deep x 24" high (with 1.5" legs and 1.5" wall brackets)